

REVISIONS					
REV.	DATE	ECN #	DESCRIPTION	BY	APP'D
1	9/14/2020	HJ20-218	REVISED HOWARD PART NUMBERS	MAD	CJT
2	1/19/2021	HJ20-224	GASKET GROOVE WAS 3/16"DP X Ø3.75"ID X Ø4.50"OD	CLS	JDD
3	6/2/2021	HJ21-110	CHANGED RATING FROM 1.2KV TO 2.5 KV	BLG	LO
4	6/29/2022	HJ22-099	TOLERANCE WAS ±.03"	MAD	CJT

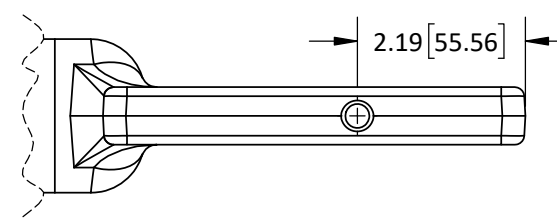
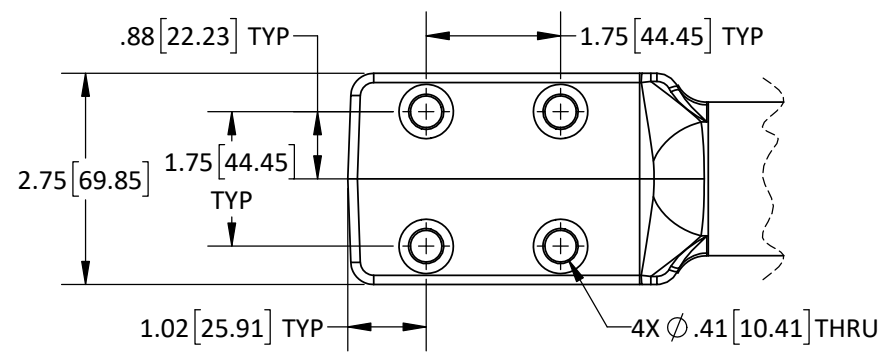
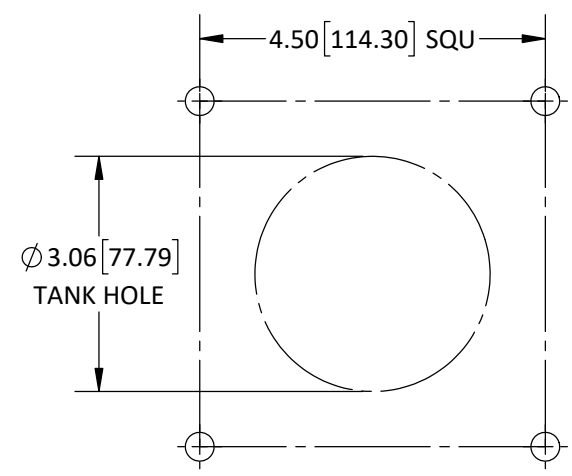

- NOTES:**
- 1) ALL UNSPECIFIED RADII TO BE R0.125
 - 2) ALL CONTACT SURFACES TO BE CLEAN & FREE FROM FLASH
 - 3) RATINGS BASED ON SIDE MOUNTED BUSHINGS WITH OIL IMMERSED SHANK AND SUITABLE TERMINATION AND LEAD CONNECTIONS

- MATERIAL:**
- 1) EPOXY, GREY (INDOOR)
 - 2) 443 OR A356-T6 ALUMINUM (CONDUCTOR) - TIN PLATED
 - 3) 356.1 CAST ALUMINUM (CLAMP)

- SPECIFICATIONS:**
- 1) BASIC IMPULSE LEVEL 45kV
 - 2) CONTINUOUS CURRENT RATING 3010A
 - 3) TEMPERATURE CLASSIFICATION -40 °C TO 120 °C

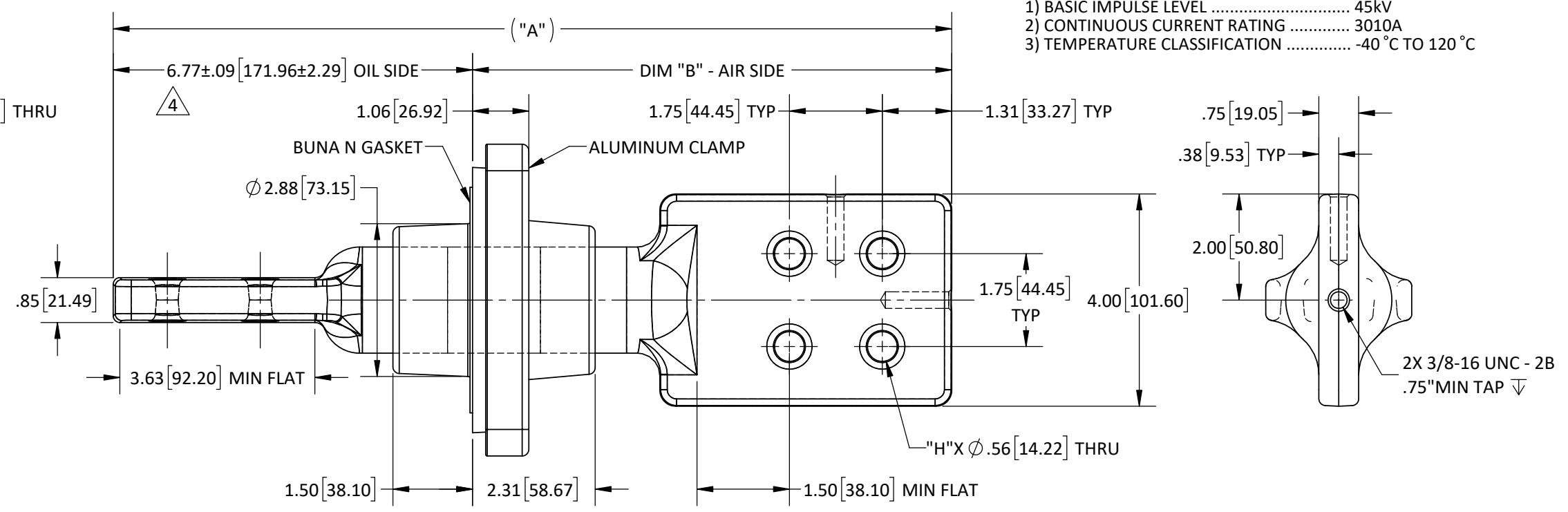
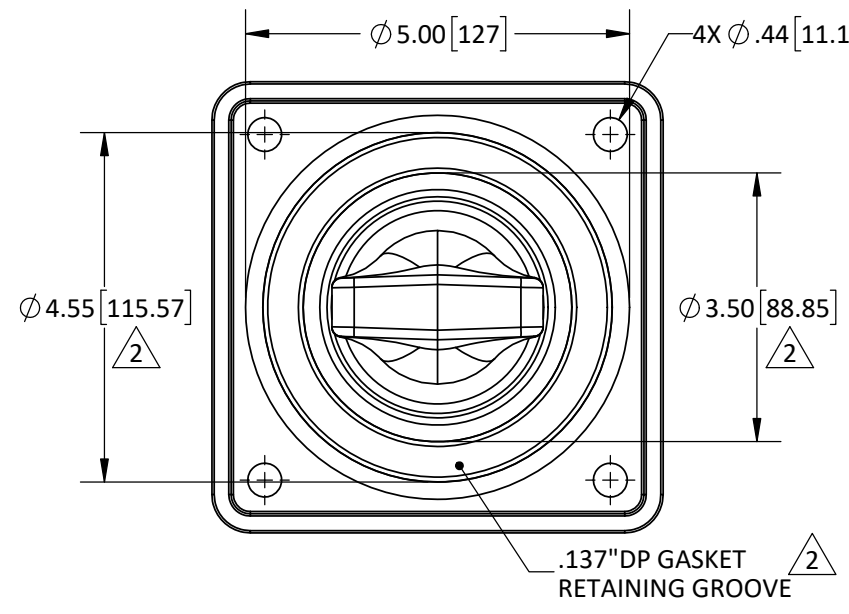

PART #	DIM "A"	DIM "B"	# OF HOLES "H"
10-504-150	15.80	9.03	4
10-504-151	17.55	10.78	6
10-504-152	19.30	12.53	8
10-504-153	21.05	14.28	10
10-504-154	22.80	16.03	12
10-504-155	24.55	17.78	14
10-504-156	26.30	19.53	16
10-504-157	28.05	21.28	18
10-504-158	29.80	23.03	20

PROPRIETARY AND CONFIDENTIAL

THE INFORMATION CONTAINED IN THIS DRAWING IS THE SOLE PROPERTY OF H-J INTERNATIONAL, INC. ANY REPRODUCTION IN PART OR AS A WHOLE WITHOUT THE WRITTEN PERMISSION OF H-J INTERNATIONAL, INC. IS STRICTLY PROHIBITED.

BREAK ALL SHARPS UNLESS OTHERWISE NOTED

THIRD ANGLE PROJECTION

ONE PLACE MM	±1.50
TWO PLACE MM	±0.75
TWO PLACE DEC.	±.060
THREE PLACE DEC.	±.030
FRACTIONS	± 1/16"
ANGLES	2°



APPROVED BY	DATE
CHECKED BY CJT	DATE 9/05/2017
DRAWN BY TJF	DATE 9/05/2017
TOOL NO.	T10-504-1
PRODUCT GRP.	1000 SERIES

H-J INTERNATIONAL, INC.
 3010 HIGH RIDGE BLVD, HIGH RIDGE, MO. 63049 USA
 PHONE 1-636-677-3421 FAX 1-636-376-1915

2.5kV / 3010A
 SECONDARY BUSHING
 (ALUMINUM CONDUCTOR)

DRAWING NO. **10-504-150**

SCALE 1:2.5 SIZE B REV. 4 SHEET 1 OF 1